

HD 9216

INSTRUCTION MANUAL



HD 9216

THERMOHYGROMETER

ENGLISH

The thermohygrometer HD 9216 is a very compact portable instrument. Its high technological features are accompanied by a pleasing design. With its range of interchangeable probes, it is an indispensable instrument for measuring temperature and humidity in the fields of maintenance, heating/air-conditioning, laboratories, food and agriculture and all other sectors where relative humidity and temperature measurements must be precise, fast and repeatable. The HD 9216 is an easy instrument to use, even for unskilled operators.

The humidity sensor is a condenser the dielectric of which is a hygroscopic polymer. As the dielectric constant for water is around 80, a strong variation of capacity is obtained with the variation of the humidity content of this polymer.

The particular advantages of this type of sensor are good linearity, repeatability, insensitivity to temperature variations, brief response time and long life. The temperature is measured by a Platinum Pt100 thermoresistance (100 Ω at 0°C); the temperature working range is limited by the temperature working range of the humidity sensor. Both the relative humidity and the temperature sensor are flat, with a high surface/volume ratio; this allows a good response time.

CHARACTERISTICS

- Instrument measuring range with probe HD 9216S:
 - relative humidity: 5%...98%.
 - temperature: -10°C...+70°C.
 - temperature with the TP 9... series of probes: from -50°C to 200°C.
- Resolution: 0.1°C in temperature, 0.1% R.H.
- HOLD button for holding the reading.
- Temperature reading in °C or °F.
- Instrument switches off automatically after 8 minutes.
- Relative humidity is measured with a capacitive sensor, temperature with a Platinum Pt100 sensor (100 Ω at 0°C); for both sensors the probe HD 9216S is amplified and linearized, while in the TP 9... probes the Pt100 sensor enters directly with a 4-wire connection.
- High precision.
- Range of probes available: for measuring relative humidity of the air, **HD 9216S, HD 9216 SAT and HD 9216 SS500**; for measuring temperature, immersion, surface contact and penetration (pointed) probes, the TP 9... series of probes, all with 4 - wire connection and precision in accordance with standards IEC 751/1983, BS 1904/1984, DIN 43760/1980 in precision classes A, 1/3 DIN.
- Low battery charge warning light.
- Battery power supply.

TECHNICAL DATA

- LCD display with 3 ½ digits, height 8 mm.
 - Measuring range: humidity 5%...98% R.H., temperature -10°C...+70°C.
 - Resolution: 0.1 R.H.
 - * Relative humidity precision, instrument complete with probe HD 9216S in the range: 5%...90% R.H.: ±2.5% R.H.
90%...98% R.H.: +4% -2% R.H.
 - ** Response time: R.H. from 45% to 90% at 63.3% of the final value 2 seconds.
 - Temperature coefficient of the humidity probe in the range 0÷40°C: ±0.05% R.H./°C.
 - Range of the temperature sensor of the probe HD 9216S: -10°C ...+70°C (14°F 158°F).
 - Temperature precision: ±0.1°C plus linearization error (0.04°C) ±1 digit.
 - Resolution: 0.1°C or 0.1°F.
 - Response time: 30 seconds at 63.3% of the final value (air moving at a speed of 1 m/second).
 - Temperature measurement range with the TP 9... series of probes: from -50°C to +200°C, from -60°F to +300°F.
 - Precision: **the total precision of the instrument plus the probes is given by the sum of the instrument error plus the error of the chosen probe depending on whether the probe is class A, 1/3 DIN.**
Precision of the instrument alone with environment temperature from 18°C to +25°C for the measuring range -50°C +200°C: ±0,1°C ±0,1% of the reading ±1 digit.
 - Influence of the environment temperature in the field from -5°C to 18°C and from +25°C to +50°C: max ±0,04°C/°C.
 - Instrument working temperature: -5°C...+50°C.
 - Storage temperature: -20°C...+60°C.
 - Relative humidity: 0÷90% R.H.
 - Number of conversions: 2.5 per second.
 - Power supply: 9V battery, IEC 6LF22, zinc-carbon battery life approx. 100 hours.
 - Low battery charge warning light.
 - Instrument connector: male 8-pole circular connector DIN 45326.
 - Case: ABS Bayer NOVODUR, grey 7553CF.
 - Dimensions: instrument 42x185x23 mm weight 130 grams.
- Kit 260x140x30 - weight 400 grams.**

* This precision refers to measurements lasting less than 15 minutes. If the hygrometric sensor is exposed to humidity levels close to saturation for periods of over 30 minutes, an excess deviation of up to +6% R.H. is measured. This deviation is memorized in the sensor when normal humidity levels are regained (lower than 90% R.H.). The sensor resumes its original characteristics if it is exposed to humidity levels lower than 80% R.H. for about 24 hours.

** **This response time refers to a measurement taken in air at a constant temperature.** For a correct measurement the temperature of the hu-

midity sensor must be the same as the temperature of the air of which you want to determine the humidity. Temperature differences between sensor and air cause errors in measurement since the temperature influences the relative humidity of the air.

ORDER CODE

- **HD 9216:** Instrument complete with probe HD 9216S for temperature and relative humidity, zinc-carbon battery, instructions and case.
- **HD 9216S:** Spare probe for the instrument HD 9216.
- **HD 9216SAT/500:** Interchangeable humidity and temperature probe; can measure relative humidity in the temperature range from -30°C to $+130^{\circ}\text{C}$, diam. 12x500 mm.
- **HD 9216 SS500:** Interchangeable humidity and temperature probe sword type $-10\dots+70^{\circ}\text{C}$ \square 18x4 L=500 mm.

For calibration the following saturated solutions are necessary:

HD 11 corresponding to 11.3% R.H. at 20°C .

HD 33 corresponding to 33.0% R.H. at 20°C .

HD 75 corresponding to 75.4% R.H. at 20°C .

IMMERSION PROBE

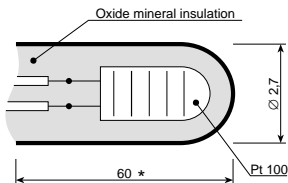

* Minimum length of immersion to perform measurement correctly

PENETRATION PROBE

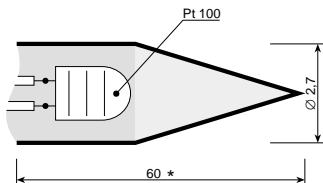

* Minimum length of penetration to perform measurement correctly

SURFACE PROBE

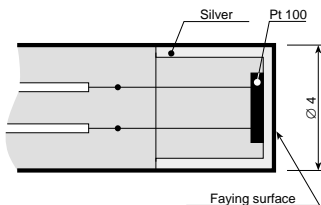



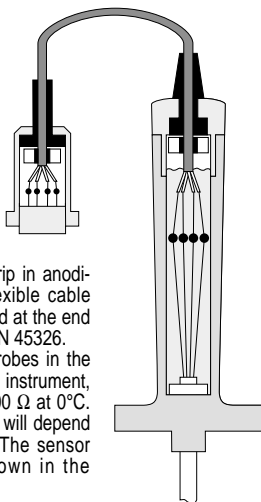







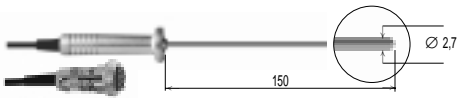

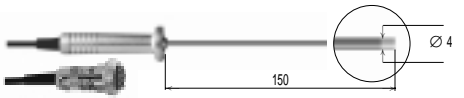
The probe and connector are assembled as in the drawing.

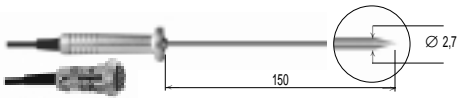

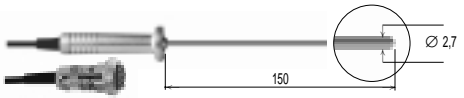
The temperature probes in the TP 9... series are composed of a Pt100 Platinum sensor (100 Ω at 0°C), tubular sheath in stainless steel AISI 316, a grip in anodized anticorodal UNI 9006/4 and a flexible cable diam. 4 mm, length 1500 mm, completed at the end by a female 8-pole circular connector DIN 45326. Respecting the connections, various probes in the TP 9... series may be connected to the instrument, as long as they are always Platinum 100 Ω at 0°C. In this case the precision of the probes will depend on the precision of the sensor used. The sensor housing inside the probe is as shown in the drawings.

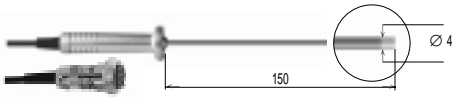
COD.	WORK RANGE	τ ** sec.	IEC 751/1983 BS 1904/1984 DIN 43760/1980
TP 9A	-70°C...+400°C	3,5"	CLASS A
TP 9AC	-70°C...+400°C	5,5"	CLASS A
TP 9AP	-70°C...+400°C	4"	CLASS A
TP 93	-70°C...+400°C	3,5"	CLASS 1/3 DIN
TP 93C	-70°C...+400°C	5,5"	CLASS 1/3 DIN
TP 93P	-70°C...+400°C	4"	CLASS 1/3 DIN

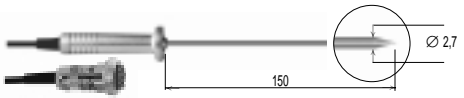



** Time constant to respond at 63% of the variation of the final temperature.
The response times refer as follows: - For immersion probes, to water at 100°C.
- For surface probes, to contact with a metal surface at 200°C.

DIMENSIONS		USE
		
		
		
		
		
		

COD.	WORK RANGE	τ ** sec.	IEC 751/1983 BS 1904/1984 DIN 43760/1980
TP 932	-70°C...+200°C	3,5"	CLASS 1/3 DIN
TP 932P	-70°C...+200°C	4"	CLASS 1/3 DIN
		% RH	
HD 9216S	-20°C...+80°C	5%...98%	Air probe, plastic container
HD 9216 SAT/500	-30°C...+130°C	5%...98%	Grains probe, stainless container
HD 9216 SS500	-20°C...+80°C	5%...98%	Sword probe, stainless steel container

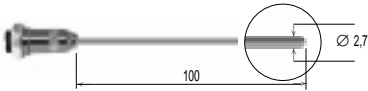
* At temperatures of over 400°C, avoid violent knocks or thermal shock as these may cause irreparable damage to the sensor.

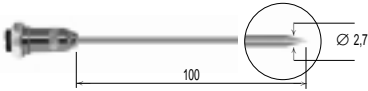
NOTE: At maximum temperature, measurements may be taken only for short periods.

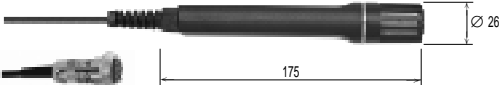
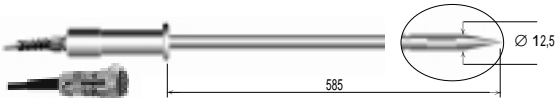
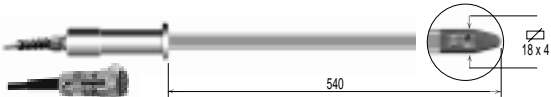
DIMENSIONS	USE
	
	
	
	
	

**Tolerances for Platinum Resistance Detectors to IEC 751 (1983)
BS 1904 (1984) and DIN 43760 (1980)**

Temp °C	Tolerance									
	CLASS B		CLASS A		1/3 DIN		1/5 DIN		1/10 DIN	
	+/- °C	+/- OHMS	+/- °C	+/- OHMS	+/- °C	+/- OHMS	+/- °C	+/- OHMS	+/- °C	+/- OHMS
-200	1.3	0.56	0.55	0.24	0.44	0.19	0.26	0.11	0.13	0.06
-100	0.8	0.32	0.35	0.14	0.27	0.11	0.16	0.06	0.08	0.03
0	0.3	0.12	0.15	0.06	0.1	0.04	0.06	0.02	0.03	0.01
100	0.8	0.3	0.35	0.13	0.27	0.1	0.16	0.05	0.08	0.03
200	1.3	0.48	0.55	0.2	0.44	0.16	0.26	0.1	0.13	0.05
300	1.8	0.64	0.75	0.27	0.6	0.21	0.36	0.13	0.18	0.06
400	2.3	0.79	0.95	0.33	0.77	0.26	0.46	0.16	0.23	0.08
500	2.8	0.93	1.15	0.38	0.94	0.31	0.56	0.19	0.28	0.09
600	3.3	1.06	1.35	0.43	1.1	0.35	0.66	0.21	0.33	0.1
650	3.6	1.13	1.45	0.46	1.2	0.38	0.72	0.23	0.36	0.11

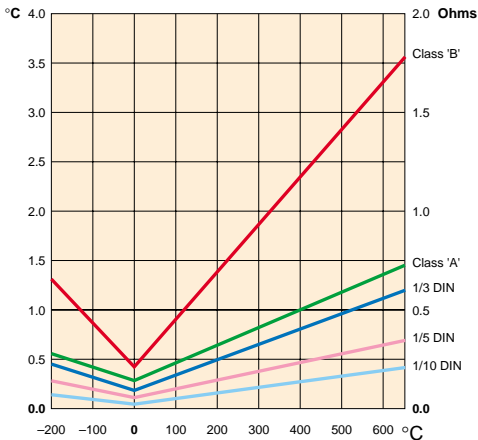

INSTRUCTIONS FOR USE

FUNCTIONS OF THE BUTTONS AND SYMBOLS

Button

Symbol

Function description



When the button is pressed the instrument switches over to measuring temperature in °C and the symbol ▼ lights up, indicating °C.



When the button is pressed the instrument switches over to measuring temperature in °F and the symbol ▼ lights up, indicating °F.



When the button is pressed the instrument switches over to measuring relative humidity and the symbol ▼ lights up, indicating % RH.



When the button is pressed the symbol ▼ indicating HOLD appears. The reading is held until the HOLD button is pressed for the second time. Internally the instrument continues to update the measurement data.



When the ON/OFF button is pressed the instrument switches on or switches off.



When this symbol appears it indicates that the battery charge is reaching an insufficient level for taking correct measurements with the instrument. It is advisable to change the battery.

PROBE CONNECTION

The following probes may be connected to the HD 9216: HD 9216S, HD 9216 SAT, HD 9216 SS500 for measuring temperature and relative humidity, and the probes in the TP 9... series with different shapes and different degrees of precision.

To connect the probes, fit the DIN 45326 female 8-pole circular connector into the DIN 45326 male 8-pole circular connector on the instrument.

The connectors are polarized. When inserting or extracting the connector, the safety ring nut must be unscrewed; insertion and extraction require a certain effort, so proceed carefully so as to avoid damaging the connector.

The safety ring nut must be fitted correctly into the thread, be careful not to spoil the thread.

Probes other than those in the TP 9... series may also be connected to the instrument; in this case care must be taken with the 4-wire connections of the Pt100 sensor, while the sensor must be 100 Ω at 0°C.

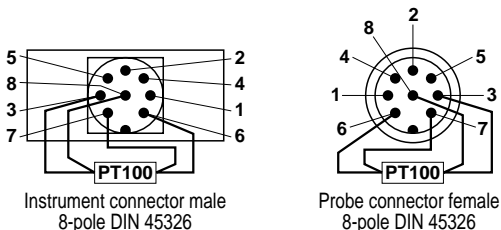

HOW TO MEASURE

To switch on the instrument, press the ON/OFF button; if the probe is connected, the instrument is now ready, depending on the probe, to measure temperature in °C or °F, or relative humidity.

When the instrument is switched on, the auto power off device is activated; this means that the instrument will switch off automatically about 8 minutes after it has been switched on. When ON/OFF is pressed the instrument switches off.

Measurement with the combined temperature and humidity probe is carried out by introducing the probe in the area where you want to record the parameters, keeping the probe away from elements that may interfere with the measurement, sources of heat or cold, walls and unexpected draughts.

Where there is no great difference in temperature the reading is almost immediate, whereas if there is a difference in temperature you must wait till the probes and the probe body have reached the same temperature, otherwise there is radiation or absorption of heat on the relative humidity sensor; this leads to errors in measurement because the temperature influences the relative humidity.

This precaution applies when taking measurements at both low and high temperatures.

The combined probes HD 9216S, HD 9216 SAT, HD 9216 SS500 are suitable for measuring temperature, relative humidity and water activity; they **are not suitable for measuring absolute humidity or for surface measurements**. The relative humidity measurement is expressed in % R.H.

Relative humidity is the ratio between the amount of vapour present in the air considered and the amount that the air could contain at the same temperature if it were saturated.

Air is defined as saturated when in those particular temperature, humidity and pressure conditions the air has absorbed the maximum possible amount of vapour.

The absolute humidity measurement is expressed in g/m^3 ; absolute humidity is calculated taking as reference the current relative humidity and the theoretical temperature conditions for the volume of humid gas at a temperature $T = 0^\circ\text{C}$ and pressure $P = 1013 \text{ mbar}$.

Absolute humidity is the weight in grams of the vapour contained in one cubic metre of air.

Dew point is the temperature at which the cooled air becomes saturated, giving rise to condensation of the excess vapour.

With the TP 9... series of probes, the measurement is taken by placing the immersion probe at a depth of at least 60 mm in the liquid of which you want to know the temperature; the sensor is at the end of the probe.

To take measurements in air, the probe must be pointed in a transverse direction to the air flow. In both cases, to obtain a correct measurement you must avoid contact of the probe with the walls.

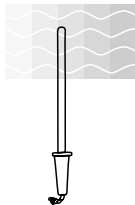
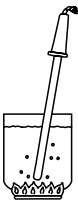

When taking penetration measurements the tip of the probe must be inserted at a minimum depth of 60 mm; the sensor is at the end of the probe.

If you have to take the measurement on frozen blocks, it is useful to use a tool to make a cavity in which you can then insert the pointed probe.

To take a surface measurement correctly, the surface concerned must be flat and smooth and the probe must be perpendicular to the point on the surface where the measurement is to be taken.

To help obtain a correct measurement, the addition of a drop of conductive paste or oil improves the response time (do not use water or solvents).

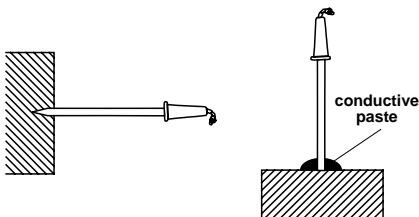

To take measurements without interruption the function AUTO POWER OFF must be activated.

The instrument will now switch off only when the ON/OFF button is pressed, so if you forget to switch it off there is a risk of finding the battery flat next time you want to use it.

- If the probe is broken or is not fitted, the display shows Err.
- If the probe is short-circuited the instrument shows the letter **!** .

USE

- Do not touch the humidity sensor with your hands.
- If a sensor is replaced, the probe must be recalibrated.
- For checking and calibration, saturated solutions are available.
- Avoid contact of the sensor surface with sticky substances or substances that can damage or corrode the condenser electrodes or the polymer.
- For normal applications of the probe HD 9216S and HD 9216 SS500, it is advisable to check calibration once a year, for the probe HD 9216 SAT/500 every 18-24 months. This operation must be carried out carefully and scrupulously by skilled personnel, following the calibration instructions exactly.
- Do not use the TP 9... series of probes in the presence of corrosive gases or liquids. The sheath in which the sensor is housed is made of stainless steel AISI 316; the sheath for surface sensors is made of AISI 316 plus silver. The grip is made of anodized anticorodal.
- Do not bend or force the contacts when fitting the connector.
- Do not bend or deform the probes as this could cause irreparable damage.
- Always use the type of probe best suited to the measurement that you wish to take.
- Pay attention to the range of use of the temperature sensors; **at extreme values, measurement is possible only for short periods.**
- At temperatures of over 400°C, avoid violent knocks or thermal shock as these may cause irreparable damage to the sensor.
- To obtain reliable temperature measurements, avoid too fast variations of temperature.
- Surface temperature probes must be held vertical to the surface where the measurement is to be taken. Apply a drop of oil or heat-conducting paste between the surface and the probe so as to improve the contact and reduce the reading time; water or solvents must absolutely not be used for this purpose.
- Measurements on non-metallic surfaces take a long time because they are poor heat conductors.
- Clean the probes carefully after use.

- This instrument is resistant to water but it is not watertight and should not therefore be immersed in water. If it should fall into the water, take it out immediately and check that no water has infiltrated.
- The temperature sensor is insulated with respect to its outer casing, be very careful not to come in contact with live parts (**above 48V**) as this could be dangerous not only for the instrument but also for the operator, who **could receive a severe electric shock**.
- Avoid taking measurements in the presence of sources of high frequency, microwaves or large magnetic fields, as the measurements would not be reliable.

LOW BATTERY WARNING AND BATTERY REPLACEMENT

If the battery voltage falls below acceptable levels, the  symbol appears. From that moment there remains about 1 hour autonomous operation.

The battery should be replaced as soon as possible; if it is not changed, as the voltage falls the data shown are no longer correct and the battery symbol disappears.

The battery used is an ordinary 9V zinc-carbon battery IEC 6LF22.



To change the battery, unscrew the cross-slotted screws in the battery compartment door



and open the door;



replace the old battery with a new one.
After replacing it, close the door, inserting the tag on the door into the slot provided in the instrument, and tighten the screw that holds the door shut.



Ensure that the instrument is switched off before changing the battery. Put the old battery in the special collection bin, thus helping to defend nature and the environment.

WARNING

- If the instrument is not to be used for a long time the battery must be removed.
- If the battery is flat it must be replaced immediately.
- Take steps to avoid leakage of liquid from the battery.
- Use good quality leakproof batteries.

MAINTENANCE

Storage conditions:

- Temperature: -20°C ... $+60^{\circ}\text{C}$.
- Humidity: less than 85% relative humidity.
- Do not store the instrument in places where:
 - 1) There is a high degree of humidity.
 - 2) The instrument is exposed to direct sunlight.
 - 3) The instrument is exposed to a source of high temperature.
 - 4) There are strong vibrations.

The instrument body is made of plastic so it must not be cleaned with solvents which can spoil plastic.

CALIBRATION OF THE COMBINED TEMPERATURE AND HUMIDITY PROBE

A. Instructions for calibration of the RELATIVE HUMIDITY section of combined Relative Humidity / Temperature probes in the series HD 9216S... with saturated solutions of salts of SODIUM CHLORIDE (75.4%), MAGNESIUM CHLORIDE (33%), and LITHIUM CHLORIDE (11.3%) with three calibration points.

Foreword: The procedure for calibrating the probes is quite simple, but in order to achieve correct calibration it is fundamental to know and respect the physical phenomena involved in measuring relative humidity. **We strongly advise you not to have the instrument adjusted by people who are not sufficiently trained or who do not have adequate technical knowledge.**

The calibration sequence with three points is performed in the following order:

1st calibration	solution with 75.4% R.H. (HD 75)
2nd calibration	solution with 33% R.H. (HD 33)
3rd calibration	solution with 11.3% R.H. (HD 11)

The first calibration point is always 75.4% R.H.

For correct calibration it is very important for the environment temperature to be stable and for both the saturated solution and the probe to be calibrated to be at the same temperature. We recommend 20°C.

Calibration sequence:

- 1) Unscrew the sensor protection.
- 2) Screw the perforated cap and its threaded ring nut into place, right down to the base.
- 3) Open the cap of the 75.4% R.H. saturated solution.
- 4) Check that there are no drops of solution inside the measuring chamber; if there are any, dry them with absorbent paper.
- 5) Insert the probe in the container, ensuring that the cap with the probe goes down to the base. The measuring chamber must be perfectly closed, otherwise it will not become saturated. It is fundamental that there be non possibility of air getting in from outside.
- 6) **Wait 30 minutes.**
- 7) Open the door of the compartment housing the calibration trimmers using a suitably sized cross-head screwdriver.
- 8) The probe is connected to the instrument. Switch on the instrument. Ensure that the measurement is stable.
- 9) Using a small screwdriver, set the calibration trimmer for the value of 75.4% R.H. The trimmer can rotate through 270°. **Do not try to force the stop, as this would break the slot for the screwdriver.** Turn the trimmer until the value indicated by the instrument coincides with the

one on the chart corresponding to the temperature of the sensor and of the saturated solution.

- 10) Ensure that the measurement is stable; wait a few minutes, then go on to calibrate the second point.
- 11) Take the probe out of the container, close the container with its cap and open the container of the saturated solution with 33% R.H. Check that there are no drops of solution inside; if there are any, dry them with absorbent paper.
- 12) Insert the probe in the container, ensuring that the probe and the cap go perfectly down to the base. The measuring chamber must be perfectly closed, otherwise it will not reach equilibrium. This is fundamental.
- 13) **Wait 30 minutes.**
- 14) Switch on the instrument and ensure that the measurement is stable.
- 15) Using a small screwdriver, set the calibration trimmer for the value of 33% R.H. until the value indicated by the instrument coincides with the one on the chart corresponding to the temperature of the sensor and of the calibration solution. **The trimmer can rotate through 270°; do not try to force the stop, as this would break the slot for the screwdriver.**
- 16) Ensure that the measurement is stable; wait a few minutes, then go on to calibrate the third point.
- 17) Take the probe out of the container, close the container with its cap and open the container of the saturated solution with 11.3% R.H. Check that there are no drops of solution inside; if there are any, dry them with absorbent paper.
- 18) Insert the probe in the container, ensuring that the probe and the cap go perfectly down to the base. The measuring chamber must be perfectly closed, otherwise it will not become balanced. This is fundamental.
- 19) **Wait 30 minutes.**
- 20) Switch on the instrument and ensure that the measurement is stable.
- 21) Using a small screwdriver, set the calibration trimmer for the value of 11.3% R.H. until the value indicated by the instrument coincides with the one on the chart corresponding to the temperature of the sensor and of the calibration solution. **The trimmer can rotate through 270°; do not try to force the stop, as this would break the slot for the screwdriver.**
- 22) Ensure that the measurement is stable; wait a few minutes. Switch off the instrument, remove the probe from the container. Close the container with its cap.
- 23) Unscrew the ring nut with the cap, screw on the sensor protection and close the door of the calibration trimmer compartment. This operation concludes calibration.

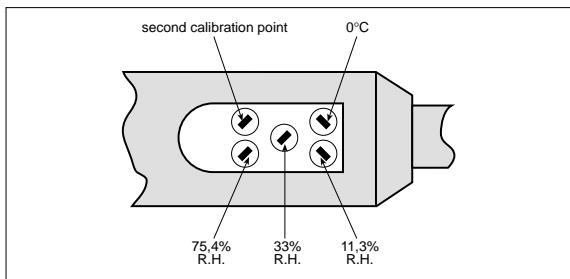

1



4

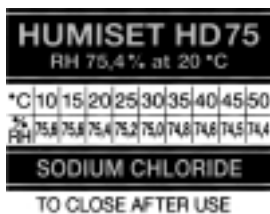

2



5



3



6



7



10



8



11

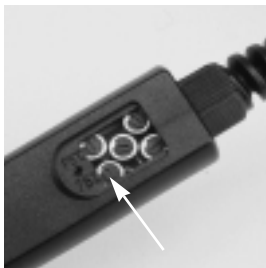

9

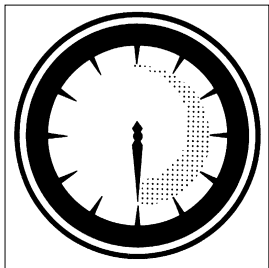

12



13



16

HUMISET HD33									
RH 33,0% at 20 °C									
°C	10	15	20	25	30	35	40	45	50
% RH	33,4	33,3	33,0	32,7	32,4	32,0	31,5	31,1	30,5

MAGNESIUM CHLORIDE

TO CLOSE AFTER USE 

14



17



15



18



19



22



20

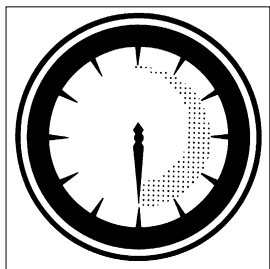

23



21

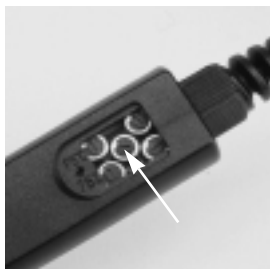

24



25

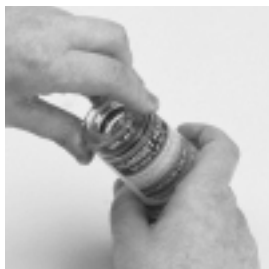

28



26

HUMISET HD 11									
RH 11,3 % at 20 °C									
°C	10	15	20	25	30	35	40	45	50
RH	11,3	11,3	11,3	11,3	11,3	11,3	11,3	11,3	11,3
LITHIUM CHLORIDE									
TO CLOSE AFTER USE 									

29



27



30

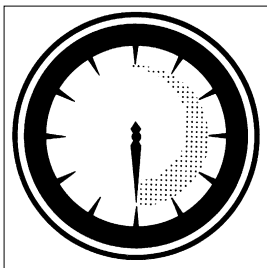

31

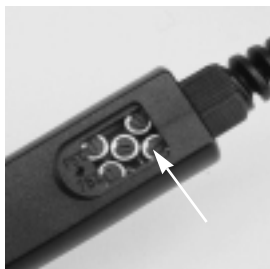

34



32



35

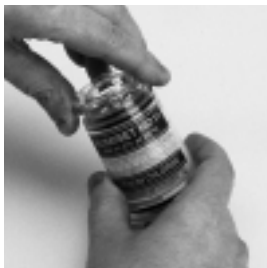

33



36



37



38



IMPORTANT NOTES

- * Do not touch the R.H. sensor with your hands.
- * The base of the R.H. sensor is made of glass, it breaks very easily.
- * **During the entire calibration cycles, work as much as possible at a constant temperature;** plastics are generally bad heat conductors, so it takes some time for them to reach a given temperature and remain stable.
- * Temperature influences the humidity measurement.
- * If you do not succeed in staying within the calibration values, the possible causes may be the following:
 - A) The sensor is faulty, corroded or broken.
 - B) During calibration the measurement chamber was not perfectly closed, that is air was getting in.
 - C) The saturated solutions used are exhausted, that is there is no more salt, but only a dense liquid; in this state the measurement chamber cannot reach saturation.
- * Storage of the saturated solutions:

The saturated solutions must be kept, if possible, at a constant temperature of around 20°C.

Avoid leaving the container open, otherwise the lifetime of the solution will be quite short; also, a large number of drops of liquid would form inside the measurement chamber.

During transport or air freight, pressures or vacuums may tend to cause the liquid to escape from the balancing hole or from the porous septum of the measurement chamber; if this should occur, dry up the liquid with absorbent paper; even if some drops are lost the solution will still work perfectly for a long time.

Equilibrium Relative Humidity of Selected Saturated Salt Solutions from 0 to 100°C

Relative Humidity, %										
T °C	Lithium Chloride	Potassium Acetate	Magnesium Chloride	Potassium Carbonate	Magnesium Nitrite	Sodium Chloride	Potassium Chloride	Potassium Nitrate	Potassium Sulfate	
0	11.23 ± 0.54		33.66 ± 0.33	43.13 ± 0.66	60.35 ± 0.55	75.51 ± 0.34	88.61 ± 0.53	96.33 ± 2.9	98.77 ± 1.1	
5	11.26 ± 0.47		33.60 ± 0.28	43.13 ± 0.50	58.86 ± 0.43	75.65 ± 0.27	87.67 ± 0.45	96.27 ± 2.1	98.48 ± 0.91	
10	11.29 ± 0.41	23.28 ± 0.53	33.47 ± 0.24	43.14 ± 0.39	57.36 ± 0.33	75.67 ± 0.22	86.77 ± 0.39	95.96 ± 1.4	98.18 ± 0.76	
15	11.30 ± 0.35	23.40 ± 0.32	33.30 ± 0.21	43.15 ± 0.33	55.87 ± 0.27	75.61 ± 0.18	85.92 ± 0.33	95.41 ± 0.96	97.89 ± 0.63	
20	11.31 ± 0.31	23.11 ± 0.25	33.07 ± 0.18	43.16 ± 0.33	54.38 ± 0.23	75.47 ± 0.14	85.11 ± 0.29	94.62 ± 0.66	97.59 ± 0.53	
25	11.30 ± 0.27	22.51 ± 0.32	32.78 ± 0.16	43.16 ± 0.39	52.89 ± 0.22	75.29 ± 0.12	84.34 ± 0.26	93.58 ± 0.55	97.30 ± 0.45	
30	11.28 ± 0.24	21.61 ± 0.53	32.44 ± 0.14	43.17 ± 0.50	51.40 ± 0.24	75.09 ± 0.11	83.62 ± 0.25	92.31 ± 0.60	97.00 ± 0.40	
35	11.25 ± 0.22		32.05 ± 0.13		49.91 ± 0.29	74.87 ± 0.12	82.95 ± 0.25	90.79 ± 0.83	96.71 ± 0.38	
40	11.21 ± 0.21		31.60 ± 0.13		48.42 ± 0.37	74.68 ± 0.13	82.32 ± 0.25	89.03 ± 1.2	96.41 ± 0.38	
45	11.16 ± 0.21		31.10 ± 0.13		46.93 ± 0.47	74.52 ± 0.16	81.74 ± 0.28	87.03 ± 1.8	96.12 ± 0.40	
50	11.10 ± 0.22		30.54 ± 0.14		45.44 ± 0.60	74.43 ± 0.19	81.20 ± 0.31	84.78 ± 2.5	95.82 ± 0.45	
55	11.03 ± 0.23		29.93 ± 0.16			74.41 ± 0.24	80.70 ± 0.35			
60	10.95 ± 0.26		29.26 ± 0.18			74.50 ± 0.30	80.25 ± 0.41			
65	10.86 ± 0.29		28.54 ± 0.21			74.71 ± 0.37	79.85 ± 0.48			
70	10.75 ± 0.33		27.77 ± 0.25			75.06 ± 0.45	79.49 ± 0.57			
75	10.64 ± 0.38		26.94 ± 0.29			75.58 ± 0.55	79.17 ± 0.66			
80	10.51 ± 0.44		26.05 ± 0.34			76.29 ± 0.65	78.90 ± 0.77			
85	10.38 ± 0.51		25.11 ± 0.39				78.68 ± 0.89			
90	10.23 ± 0.59		24.12 ± 0.46				78.50 ± 1.0			
95	10.07 ± 0.67		23.07 ± 0.52							
100	9.90 ± 0.77		21.97 ± 0.60							

B. Instructions for calibration of the TEMPERATURE HUMIDITY section of combined Relative Humidity / Temperature probes in the series HD 9216S...

Foreword: Save in cases where the thin film platinum probe Pt100 (100 Ω at 0°C) is working in a particularly hostile or corrosive environment, or if the calibration trimmers have been tampered with, the temperature probe rarely loses calibration, so **we advise you not to take any action** unless you are sure what you are doing.

The calibration sequence is performed in the following order:

1st calibration 0°C
2nd calibration 100°C

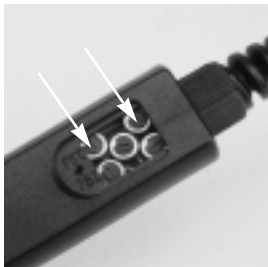
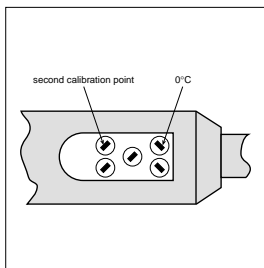

The first calibration point is always 0°C.

For correct calibration it is very important for the environment temperature to be stable and for both the probe and the simulator to be at the same temperature. We recommend 20°C.

Calibration sequence:

- 1) Unscrew the probe protection filter with the instrument switched off. Be very careful.
- 2) Carefully unsolder the temperature sensor.
- 3) In its place connect a precision Pt100 simulator.
- 4) At the probe input, simulate 0.0°C, corresponding to 100 Ω .
- 5) Open the door of the compartment housing the calibration trimmers using a suitably sized cross-head screwdriver.
- 6) The probe is connected to the instrument. Switch on the instrument. Ensure that the measurement is stable.
- 7) Using a small screwdriver, set the calibration trimmer for the value of 0°C. **The trimmer can rotate through 270°. Do not try to force the stop, as this would break the slot for the screwdriver.** Turn the

trimmer until the value indicated on the display of the instrument corresponds to 0.0°C.

- 8) At the probe input, simulate 100°C, corresponding to 138.5 Ω.
- 9) Using a small screwdriver, turn the calibration trimmer for the value of 100°C until the value indicated by the instrument corresponds to 100.0°C. **The trimmer can rotate through 270°. Do not try to force the stop, as this would break the slot for the screwdriver.**
- 10) Switch off the instrument, disconnect the Pt100 simulator and very carefully resolder the Pt100 sensor. **The Pt100 sensor used has a precision rating A according to IEC 751.**
- 11) Turn the temperature sensor at an angle of 90° towards the extreme edge of the probe so that the sensor body protrudes from the edge.
- 12) Switch on the instrument. Immerse the temperature sensor in a container full up to the brim with bidistilled water at about 20°C. The container is placed over a working agitator; a reference thermometer will be immersed in the container.
- 13) Wait a few minutes until the reading is stable, then read the value on the instrument. If the value does not coincide with the reference thermometer, turn the 0°C trimmer.
- 14) Switch off the instrument, dry the temperature sensor with soft absorbent paper and return it to its working position.
- 15) Screw on the protection filter and close the door of the calibration trimmer compartment. This operation concludes calibration of the temperature section.

Note. To calibrate the probe HD 9216 SAT/500 proceed as follows:

- 1) Unscrew the mobile ring nut that anchors the grommet, turning it in an anti-clockwise direction so as to release the pressure of the rubber ring that holds down the cable.
- 2) Unscrew the end of the grip, turning it in an anti-clockwise direction so as to obtain access to the slots in which you can then insert the screwdriver to calibrate the trimmer. **Attention: when unscrewing the end of the grip, hold the cable still (it must not turn).**

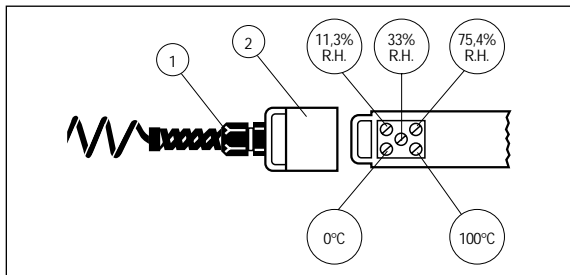

BLOCK DIAGRAM

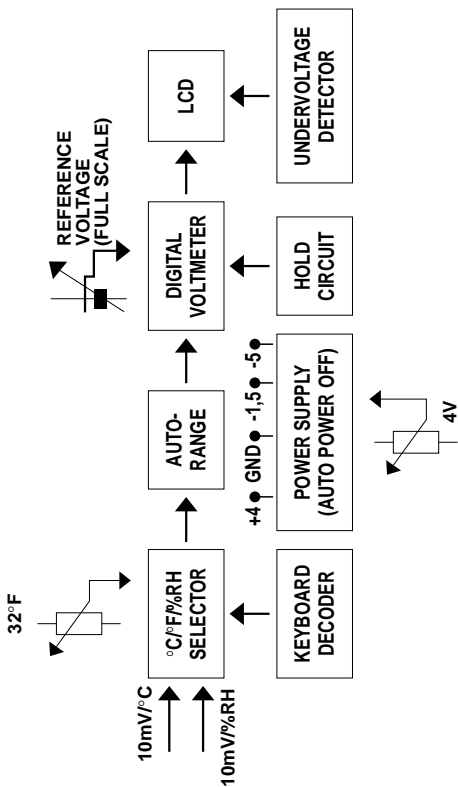

GUARANTEE

This instrument is strictly inspected before being sold. However if there should be any defect due to manufacture and/or transport, apply to the dealer from whom you bought the instrument.

The guarantee period is 2 (two) years from the date of purchase. During this period all defects found by us will be repaired free of charge, **excluding those due to incorrect use and careless handling.**

The probes are not covered by the guarantee, as they can be irreparably damaged after only a few minutes of incorrect use.

GUARANTEE CONDITIONS

All our appliances have been subjected to strict tests and are guaranteed for 24 months from date of purchase. The Company undertakes to repair or replace free of charge any parts which it considers to be inefficient within the guarantee period. Complete replacement of the instrument is excluded and no requests for damages are recognized, whatever their origin. Repairs are carried out in our own Technical Service Department. Transport expenses are borne by the buyer. **The guarantee does not include: accidental breakages due to transport, incorrect use or neglect, incorrect connection to voltage different from that contemplated for the instrument, probes, sensors, electrodes and all accessories.** Furthermore the guarantee is not valid if the instrument has been repaired or tampered with by unauthorized third parties, or adjusted for faults or casual checking. The guarantee is valid only if all parts of the guarantee card have been filled in. Any instruments sent for repairs must be accompanied by their guarantee certificate. For all disputes the competent court is the Court of Padua.

CE CONFORMITY	
Safety	EN61000-4-2, EN61010-1 level 3
Electrostatic discharge	EN61000-4-2 level 3
Electric fast transients	EN61000-4-4 level 3
Voltage variations	EN61000-4-11
Electromagnetic interference susceptibility	IEC1000-4-3
Electromagnetic interference emission	EN55020 class B



DELTA OHM SRL
 VIA G. MARCONI, 5 - 35030 CASELLE DI SELVAZZANO (PD) - ITALY
 TEL. 0039-0498977150 r.a. - FAX 0039-049635596
 e-mail: deltaohm@tin.it - Web Site: www.deltaohm.com